

JINAN MORAL MACHINERY(MORAL INTERNATIONAL)CO.,LTD

ADD:NO.57 Jibei Development Zone, Jinan City,China.
info@morallift.com www.morallift.com
Tel:0086-531-87118759 Fax:0086-531-87161382

FPC-2

Two Post Car Parking Lift

PROFESSIONAL LIFTING SOLUTION PROVIDER!



-----WE PLAN , DESIGN, MANUFACTURE AND INSTALL...



Better On Every Level

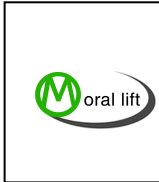

Introduction

Two Post Car Parking Lift



1. Brief introduction

Two post parking lift have two levels,you can used it to parking 2 cars. Lower cars can be parked or taken at will, if we want to park or take the upper cars, we have to take the lower cars first. Equipment max-lifting height is 2200MM, max-lifting capacity is 2700kg. Suitable for parking SUV and sedan.Equipment size can be customized by customers. This product is widely used in banks, hospitals, hotels, supermarkets, entertainment, office enterprises, public institutions and residential areas.

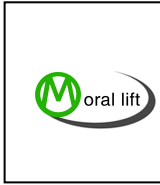

2. Statement

- The operator should operate in accordance with the requirements of this manual, otherwise any personal losses and injuries caused by the user shall be responsible for themselves.
- In order to ensure safe use, lift operators must undergo professional training and should have a high sense of responsibility. It is forbidden to operate and maintain the equipment before reading this manual in full detail or before performing a detailed safety inspection on the equipment.
- Our company provides a one-year quality guarantee period for the main structure (excluding electrical components) for this equipment. This quality guarantee is limited to quality problems caused by the equipment itself. All equipment problems caused by abnormal wear, improper use or failure to maintain as required are not covered by this warranty.

3. Introduction of the equipment

It is an simple lifting mechanical parking equipment, which is a parking product developed by us after continuous research. The equipment is simple in structure, easy to assemble, and saves space. It is very popular.

The main machine of the equipment mainly includes three parts: uprights on both sides, sliding tables on both sides and corrugated platform. The left and right uprights can be used in common use, and the left and right sliding tables can be combined with the uprights at will to form two-unit or multi-unit equipment.

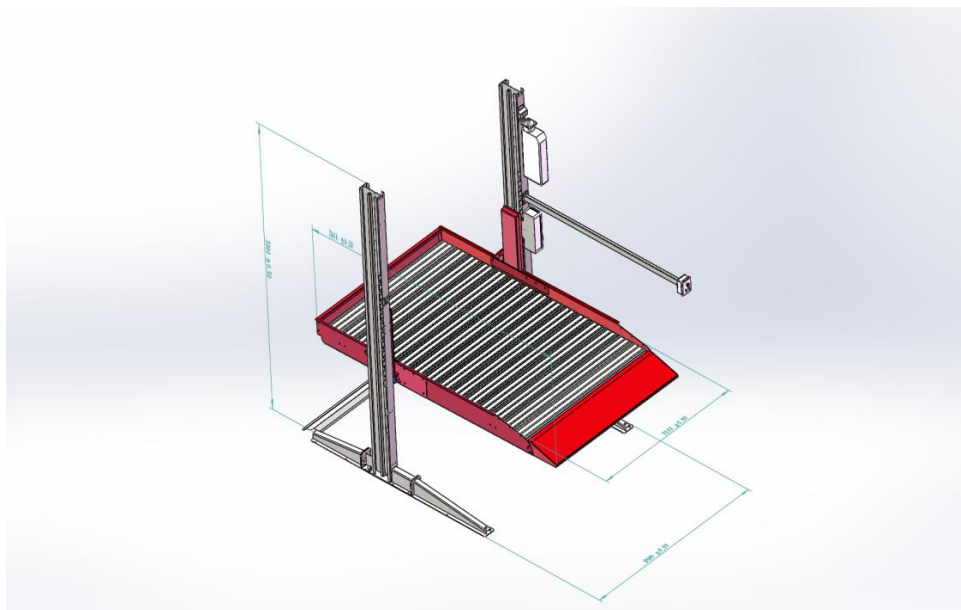

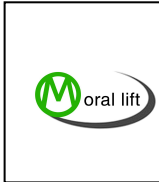

ADD:NO.57 Jibei Development Zone, Jinan City,China.
info@morallift.com www.morallift.com
Tel:0086-531-87118759 Fax:0086-531-87161382

Product Advantage

The structure of the equipment is made of laser cutting, after bending have beautiful appearance, easy installation and convenient maintenance.



The equipment adopts inverted oil cylinder to lift the platform,Cylinder seal is used in Italy Aston brand, to prevent oil spills.



Electric control, hydraulic drive, chain balance to make sure equipment running smoothly.



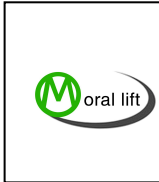

JINAN MORAL MACHINERY(MORAL INTERNATIONAL)CO.,LTD

ADD:NO.57 Jibei Development Zone, Jinan City,China.

info@morallift.com www.morallift.com

Tel:0086-531-87118759 Fax:0086-531-87161382

Unlock uses the AC24V magnet to automatically unlock both sides simultaneously.



The car platform use the totally enclosed design,to avoid leakage of rain and snow or water pollution in the lower cars.



Welding tube strengthening at the column on both sides,increase the bending strength of the column,and each column can be used interchangeably.

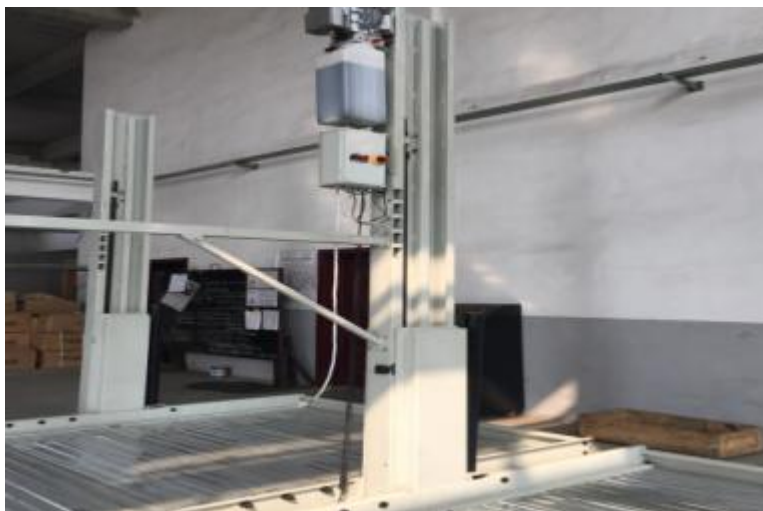

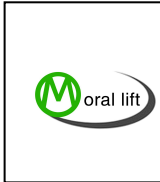

ADD:NO.57 Jibei Development Zone, Jinan City,China.

info@morallift.com www.morallift.com

Tel:0086-531-87118759 Fax:0086-531-87161382

The column can be shared and freely combined into two conjoined, three conjoined bodies or others,save costs and installation space.



Protective Device

Falling proof device:there are 6 unlock holes, automatic locking, to prevent the car platform suddenly fall.



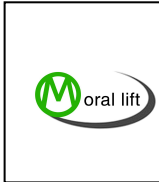

**ADD:NO.57 Jibei Development Zone, Jinan City,China.
info@morallift.com www.morallift.com
Tel:0086-531-87118759 Fax:0086-531-87161382**

Limit switch: limit car platform lifting height, we can adjust the lifting height.



Photoelectric switch:when the equipment work,if photoelectric switch feel have someone or something under the car platform,the equipment will stop running.



Water proof control box can waterproof, and have emergency stop button and self-lock button, control box have keys to prevent non managers from operating the device after locking. Column can be added to run alarm lights,(up or down).



ADD:NO.57 Jibei Development Zone, Jinan City,China.
info@morallift.com www.morallift.com
Tel:0086-531-87118759 Fax:0086-531-87161382



Main Parameters

Name	Two post parking lift
Model	FPC-2
Equipment size	4150x2566x3000mm
Lifting weight	2300kg/2700kg
Rate running	2m/min
Lifting height	2180mm
Column height	3000mm
Car platform size	3930*2100mm
Power unit motor	2.2kw
Number of hydraulic	2
Operation mode	Button/remote key (optional)
Noise	≤70dB
Control mode	Electrical control/PLC control (optional)
Derive mode	Hydraulic drive and chain balance
Power	220V/380V, 50/60 HZ 1/3 Phase
Package size	3300MM*900MM*600MM
Equipment weight	850kg
Surface treatment	Spraying paint/galvanized (optional)
Hydraulic cylinder	2 PCS Two stage intelligent inverted cylinder



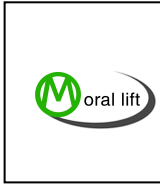

ADD:NO.57 Jibei Development Zone, Jinan City,China.
info@morallift.com www.morallift.com
Tel:0086-531-87118759 Fax:0086-531-87161382

Product drawing

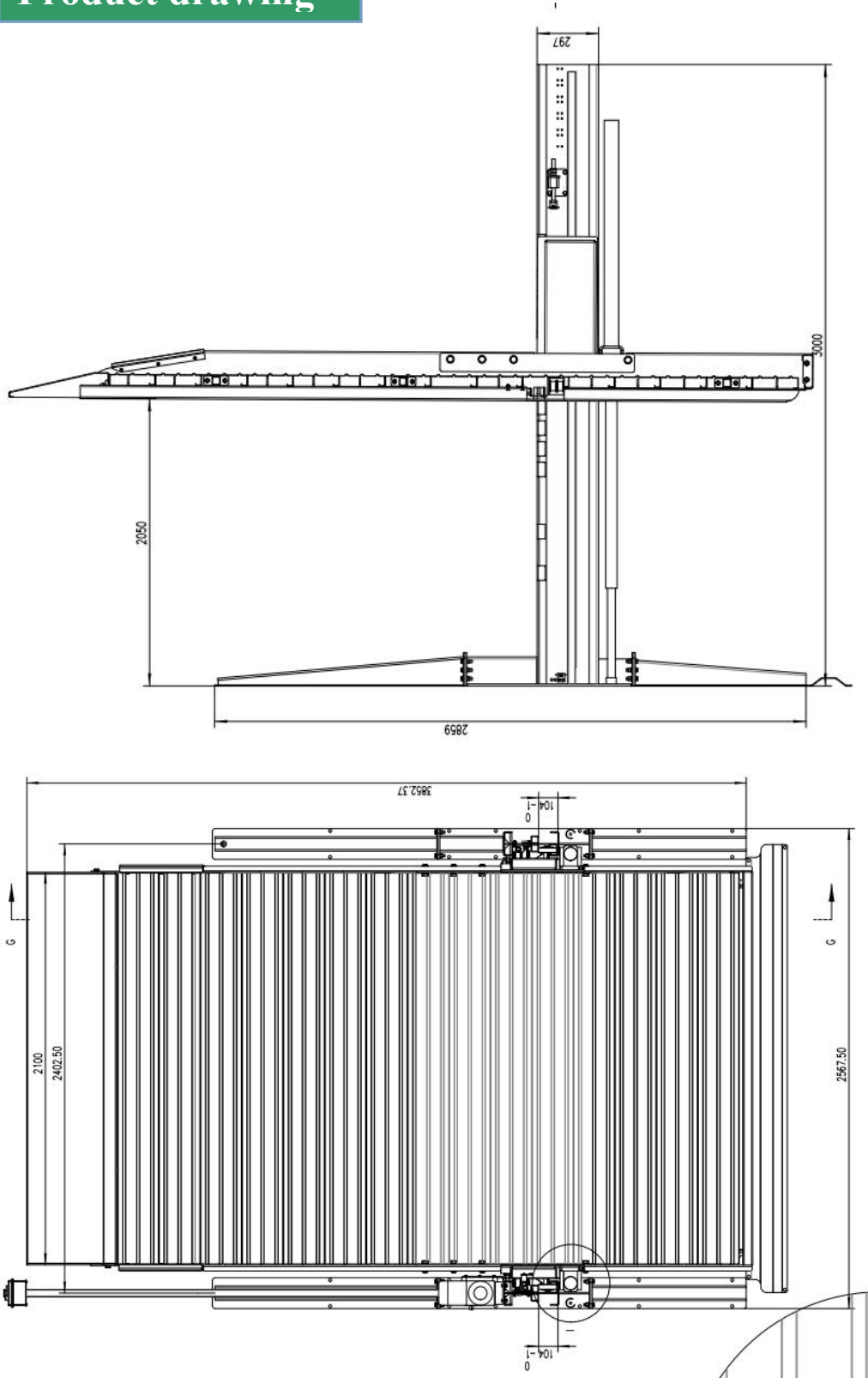

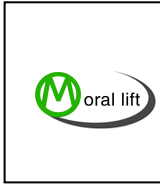

ADD:NO.57 Jibei Development Zone, Jinan City,China.
info@morallift.com www.morallift.com
Tel:0086-531-87118759 Fax:0086-531-87161382

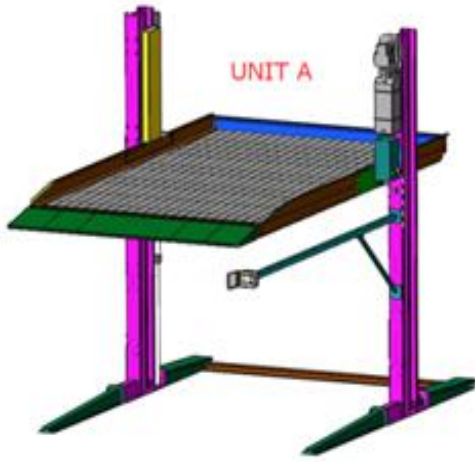

A-TWO COLUMNS

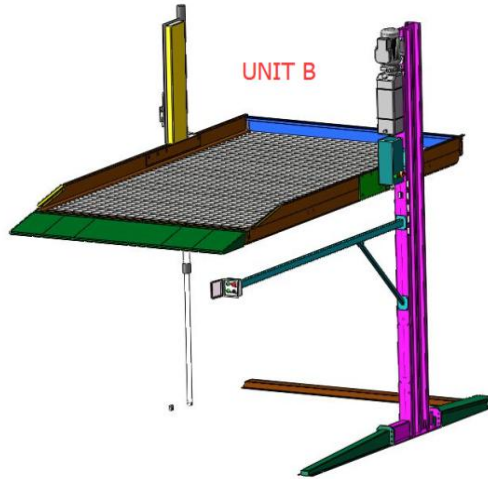

B-ONE COLUMN

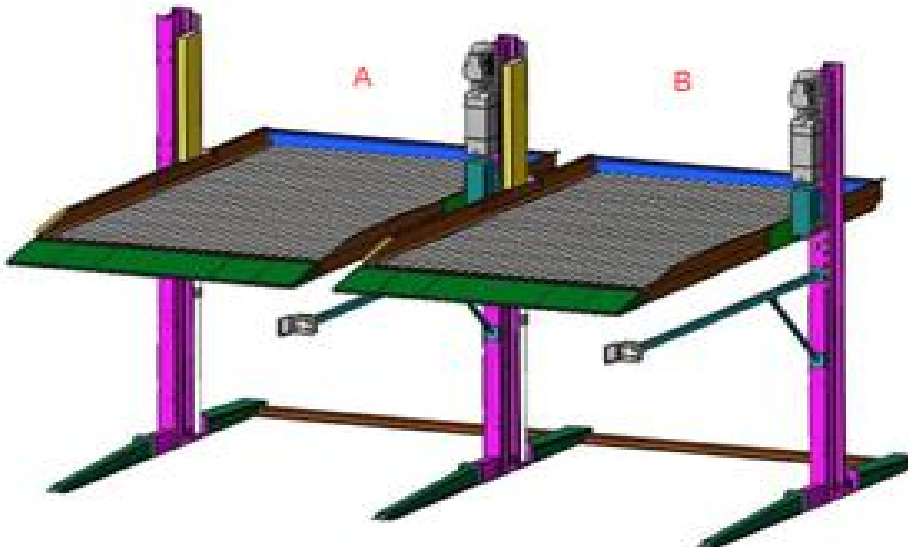

TWO UNITS EQUIPMENT SHARE COLUMN

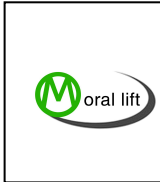

JINAN MORAL MACHINERY(MORAL INTERNATIONAL)CO.,LTD

ADD:NO.57 Jibei Development Zone, Jinan City,China.
info@morallift.com www.morallift.com
Tel:0086-531-87118759 Fax:0086-531-87161382

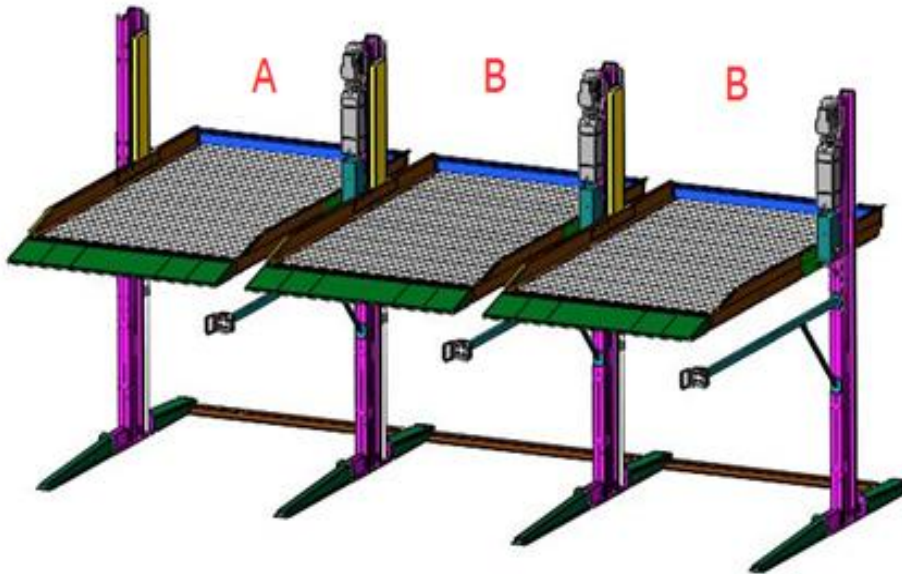

THREE UNITS SHARE COLUMNS

Schematic diagram of access vehicle:

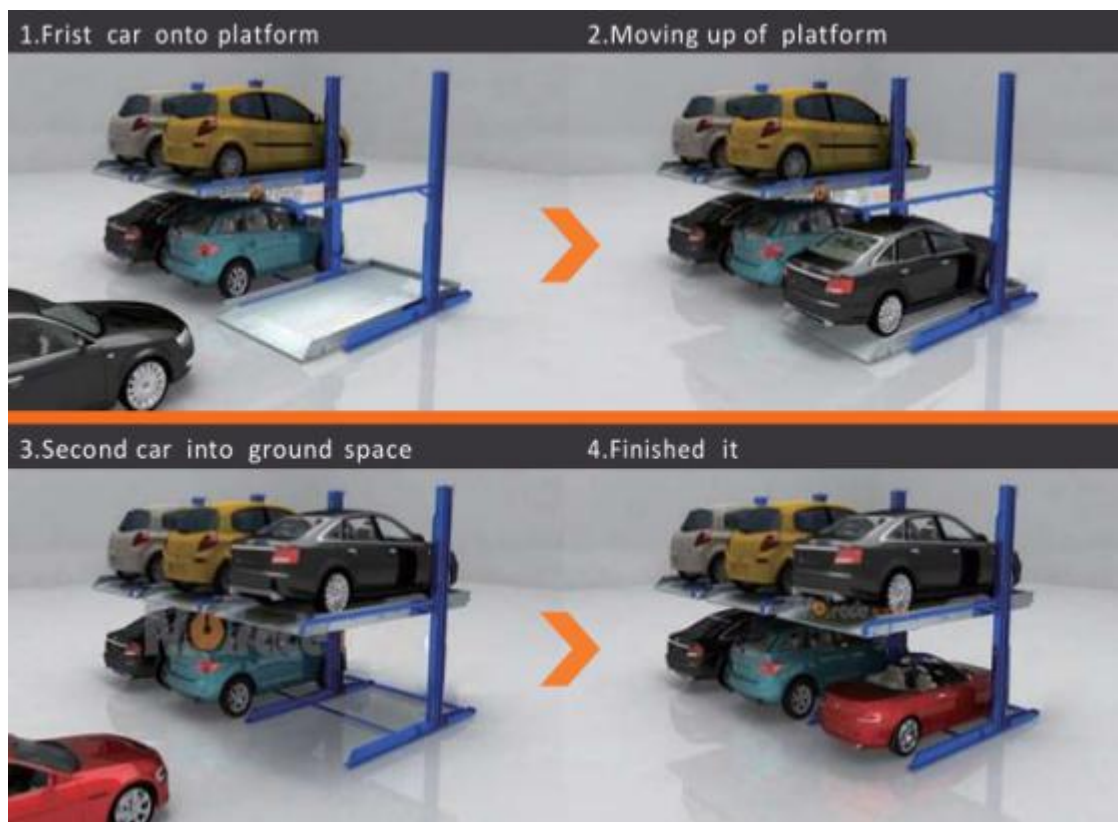

Better On Every Level

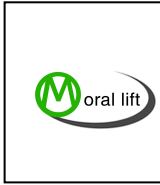

JINAN MORAL MACHINERY(MORAL INTERNATIONAL)CO.,LTD

ADD:NO.57 Jibei Development Zone, Jinan City,China.

info@morallift.com www.morallift.com

Tel:0086-531-87118759 Fax:0086-531-87161382

Project case



Better On Every Level

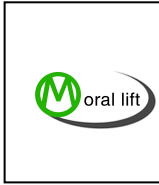

Maintenance

Regular maintenance should be carried out every month to ensure the safety of the equipment and prolong the service life of the equipment.

1. Check whether the sliding table can work normally.
2. Check whether the chain and its joints, chain pins, split pins, etc. work normally.
3. Check whether the expansion bolts are loose, if they are loose, they should be tightened.
4. Check whether the locking device can work normally. If it is not working properly, find the cause and eliminate the fault.
5. Check whether the column is deformed and whether it is perpendicular to the ground. If the column is seriously deformed due to overload or abnormal use, the equipment should be stopped.
6. Fill the sliding block in the column with a proper amount of grease.

Trouble phenomenon and repair methods

Trouble phenomenon	Reason	Repair methods
The motor rotates, there is no hydraulic leakage or abnormal sound, but the platform does not rise	Hydraulic oil contains air	Lift to the highest point without load and then land for a few seconds. When landing to half of the height, unscrew the oil pipe joint and tighten it after exhausting.
	The hydraulic oil is solidified or the viscosity of the hydraulic oil is too high due to the low ambient temperature	Drain the hydraulic oil and refill with qualified hydraulic oil
	Overweight	Check and confirm that the lifting weight is less than the rated load
Hydraulic oil leakage at tubing joints	Loose joints	Tighten the pipe joint
	Damaged connector	Replace the connector
Cylinder hydraulic leakage	Cylinder seal ring wear	Replace the sealing ring or cylinder

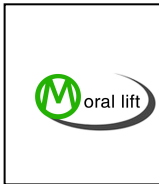

The motor does not rotate	Motor burned out	Replace the motor after checking and confirming that the power supply is correct
	Voltage is too low	Check and confirm that the voltage is the specified voltage
	Fuse blown	Replace the fuse
	The limit switch is broken	Replace limit switch
The platform does not drop	The platform is locked	After the control platform rises and unlocks, the control platform falls again
The platform drops slowly	Hydraulic oil viscosity is too large	Change to the specified hydraulic oil or consult the local hydraulic oil manufacturer.
	Power unit plug valve blocked	Disassemble the valve for cleaning (pay attention to dustproof)
	Blocked tubing or pipe joints	Unblock the tubing and tubing joints
Motor reverse	Wiring error	Modify the wiring according to the circuit diagram in the motor

Warranty

MORAL LIFT equipment has 5 years warranty on structure, and first year warranty on the whole machine. Within the warranty period, MORAL LIFT is responsible for the parts and structure, not including labor nor any other cost unless pre-agreed.

Power units, hydraulic cylinders, and all other assembly components such as slip plates, cables, chains, valves, switches etc, are warranted for one year against defects in material or workmanship under normal use. MORAL LIFT shall repair or replace at their option for the warranty period those parts returned to the factory freight prepaid which prove upon inspection to be defective. MORAL

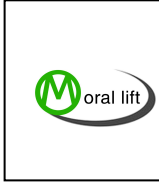

**ADD:NO.57 Jibei Development Zone, Jinan City,China.
info@morallift.com www.morallift.com
Tel:0086-531-87118759 Fax:0086-531-87161382**

LIFT will not be responsible on any labor costs unless pre-agreed. MORAL LIFT will not responsible for the modification or upgrade of the product from the client unless pre-agreed.

These warranties do not extend to...

- defects caused by ordinary wear, abuse, misuse, shipping damage, un-proper installation, voltage or lack of required maintenance;**
- damages resulting from purchaser's neglect or failure to operate products in accordance with instructions provided in the owner's manual(s) and/or other accompanying instructions supplied;**
- normal wear items or service normally required to maintain the product in a safe operating condition;**
- any component damaged in shipment;**
- other items not listed but may be considered general wear parts;**
- damage caused by rain, excessive humidity, corrosive environments or other contaminants.**
- any change or modification made to the equipment without pre-agreed.**

These warranties do not extend to any cosmetic defect not interfering with equipment functionality or any incidental, indirect,or consequential loss, damage, or expense that may result from any defect, failure, or malfunction of a MORAL LIFT product or the breach or delay in performance of the warranty.

MORAL LIFT makes no warranty on components and/or accessories furnished to MORAL LIFT by third parties. These are warranted only to the extent of the original manufacturer's warranty to MORAL LIFT. Other items not listed but may be considered general wear parts.

MORAL LIFT reserves the right to make design changes or add improvements to its product line without incurring any obligation to make such changes on product sold previously.

Warranty adjustments within the above stated policies are based on the model and serial number of the equipment. This data must be furnished with all warranty claims